

CRT 83

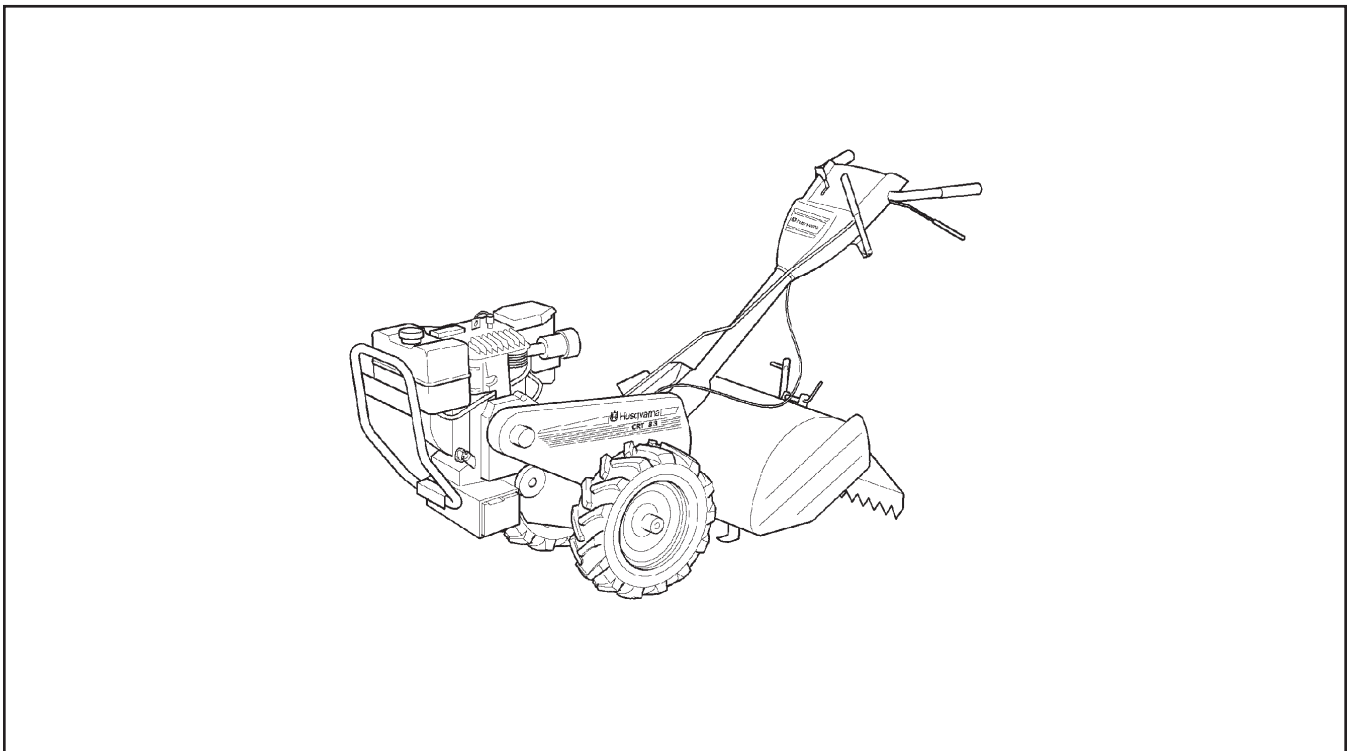

954140066C

REPAIR PARTS

TILLER - - MODEL NO. CRT83 (954140066C), PRODUCT NO. 954 14 00-66

HANDLE ASSEMBLY

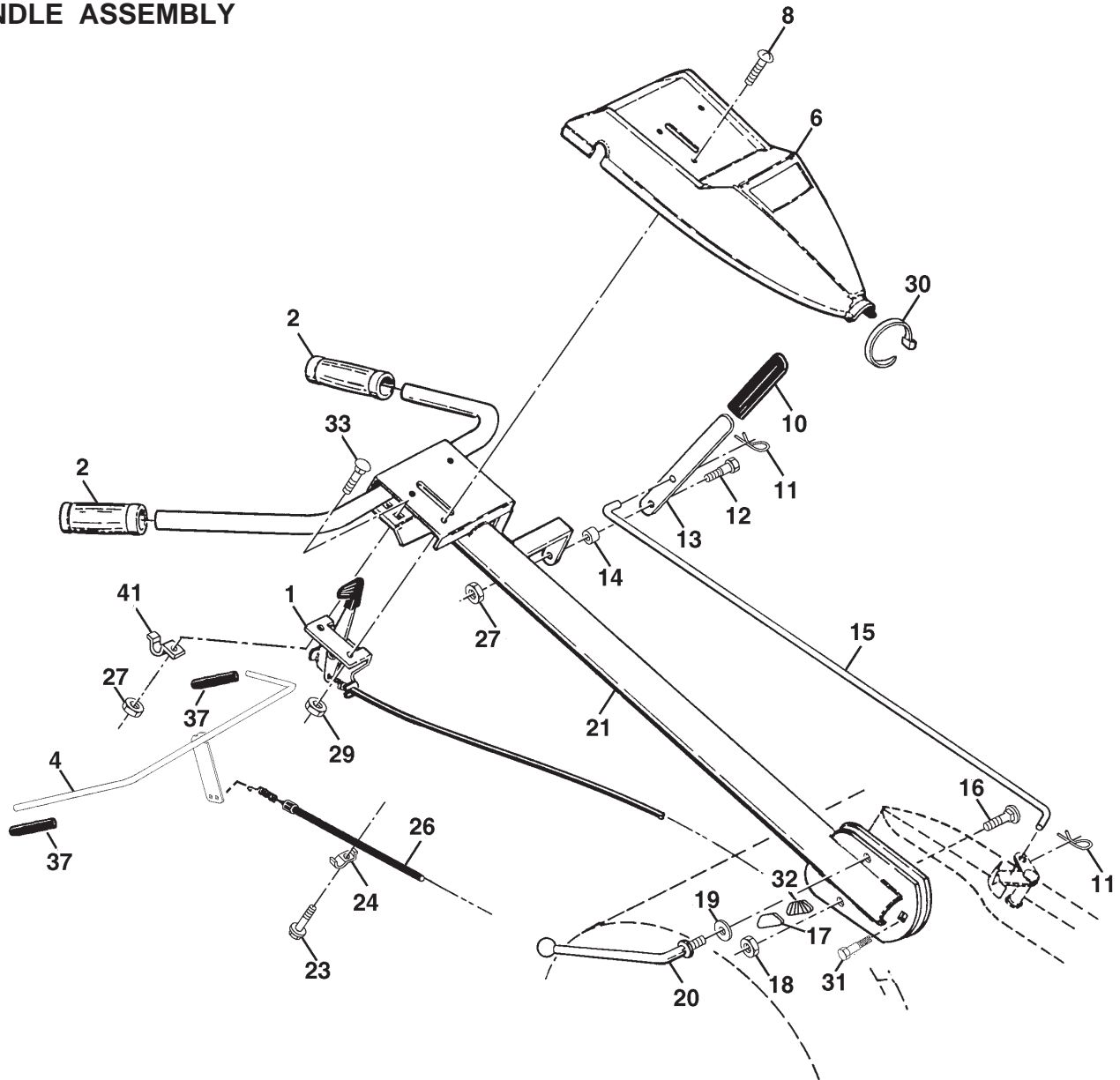

KEY NO.	PART NO.	DESCRIPTION
1	532138305	Control, Throttle
2	532009266	Grip, Handle
4	532159228	Bar Assembly, Control
6	532126956	Panel, Control
8	871191008	Screw, Pan Hd. #10-24 UNC
10	532124797	Grip, Handle
11	532124788	Clip, Hairpin
12	532081328	Bolt, Shoulder
13	532109335	Handle, Shift
14	532109313	Grommet, Rubber
15	532138400	Rod, Shift
16	872110608	Bolt, Carriage 3/8-16 x 1
17	532109229	Lock, Handle
18	873680600	Nut, Crownlock 3/8-16 UNC
19	819131611	Washer 13/32 x 1 x 11 Ga.
20	532109228	Lever, Lock, Handle

KEY NO.	PART NO.	DESCRIPTION
21	532151596	Handle
23	532170488	Screw, Hex Washer Hd. Slotted #10-24 x 1/2
24	532009484	Clip
26	532159607	Cable, Clutch
27	873900400	Nut, Hex Flange 1/4-20 UNC
29	873731000	Nut, Keps #10-24 UNC
30	532104164	Tie, Cable
31	532150696	Bolt, Pivot
32	532138283	Lock, Handle
33	872140404	Bolt, Carriage 1/4-20 UNC x 1/2
37	532102604	Grip, Bar, Control
41	532102744	Clamp, Bar, Control

NOTE: All component dimensions given in U.S. inches.
1 inch = 25.4 mm

REPAIR PARTS

TILLER - - MODEL NO. CRT83 (954140066C), PRODUCT NO. 954 14 00-66

MAINFRAME, LEFT SIDE

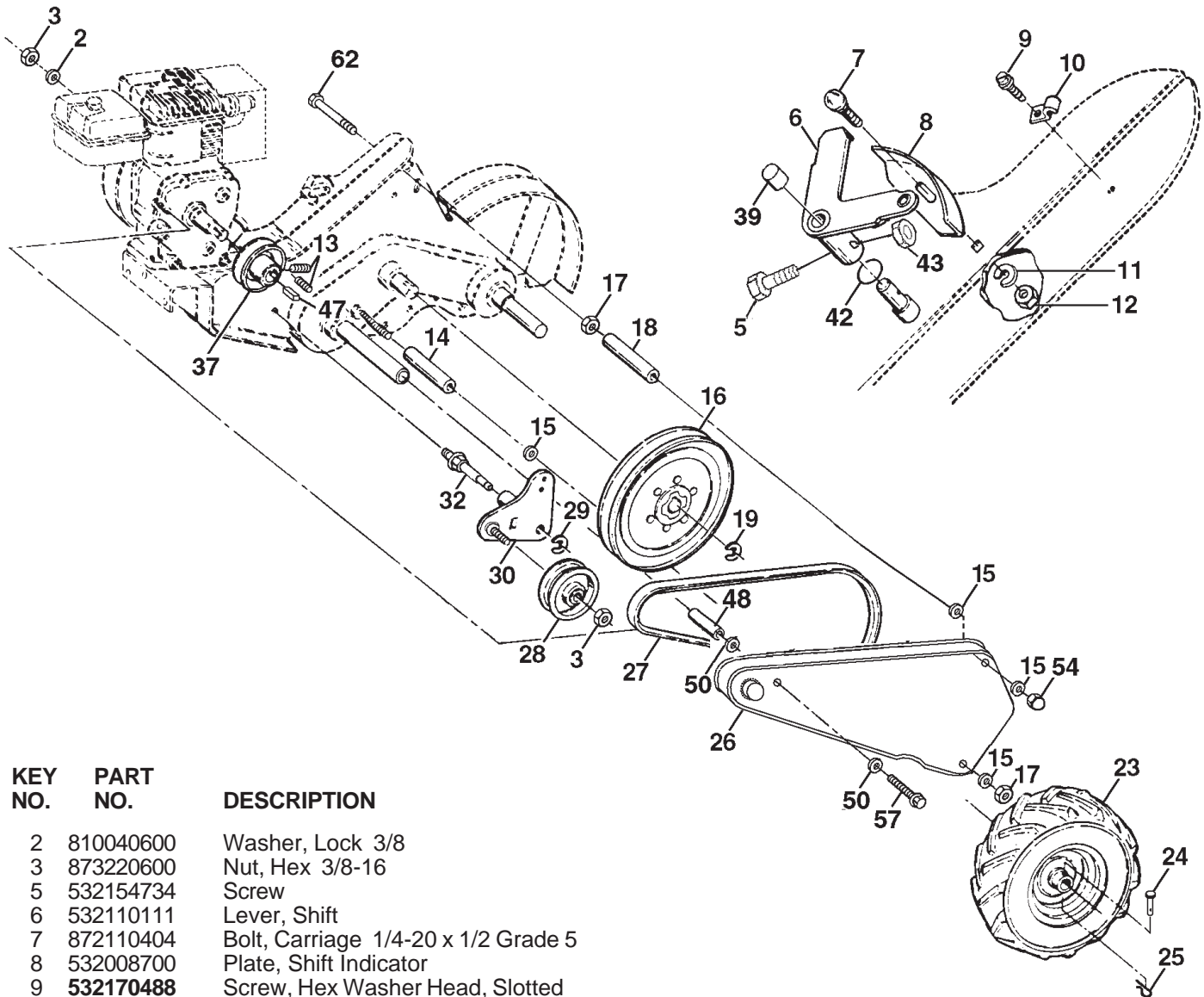

KEY NO.	PART NO.	DESCRIPTION
2	810040600	Washer, Lock 3/8
3	873220600	Nut, Hex 3/8-16
5	532154734	Screw
6	532110111	Lever, Shift
7	872110404	Bolt, Carriage 1/4-20 x 1/2 Grade 5
8	532008700	Plate, Shift Indicator
9	532170488	Screw, Hex Washer Head, Slotted #10-24 x 1/2
10	532009484	Clip
11	810040400	Washer, Lock 1/4
12	873220400	Nut, Hex 1/4-20
13	823230506	Screw, Set, Hex 5/16-18 x 3/8
14	532008382	Spacer, Split
15	819111116	Washer 11/32 x 11/16 x 16 Gauge
16	532145102	Sheave, Transmission
17	873220500	Nut, Hex 5/16-18
18	532008381	Spacer
19	812000028	Ring, Retainer
23	532005015	Tire
	532124366	Rim
	532124718	Tire Valve
24	532004929	Rivet, Drilled
25	532124961	Clip, Hairpin
26	532145518	Guard, Belt
27	532138399	V-Belt
28	532104679	Pulley, Idler
29	812000032	Ring, Klip

KEY NO.	PART NO.	DESCRIPTION
30	532159229	Bracket, Idler
32	532139401	Shaft, Idler Arm
37	532004368	Sheave, Engine
39	532140062	Cap, Plunger
42	532106160	O-Ring
43	532069180	Nut, Lock #10-24 UNC
47	532004914	Key, Square
48	532157486	Spacer, Split .523 x .718 x .700
50	819171616	Washer
54	532104214	Nut, Cap 5/16-18
57	874770844	Bolt, Hex Head 1/2-20 x 2-3/4
62	874930572	Bolt, Hex Head 5/16-18 x 4-1/2

NOTE: All component dimensions given in U.S. inches.
1 inch = 25.4 mm

REPAIR PARTS

TILLER - - MODEL NO. CRT83 (954140066C), PRODUCT NO. 954 14 00-66
 MAINFRAME, RIGHT SIDE

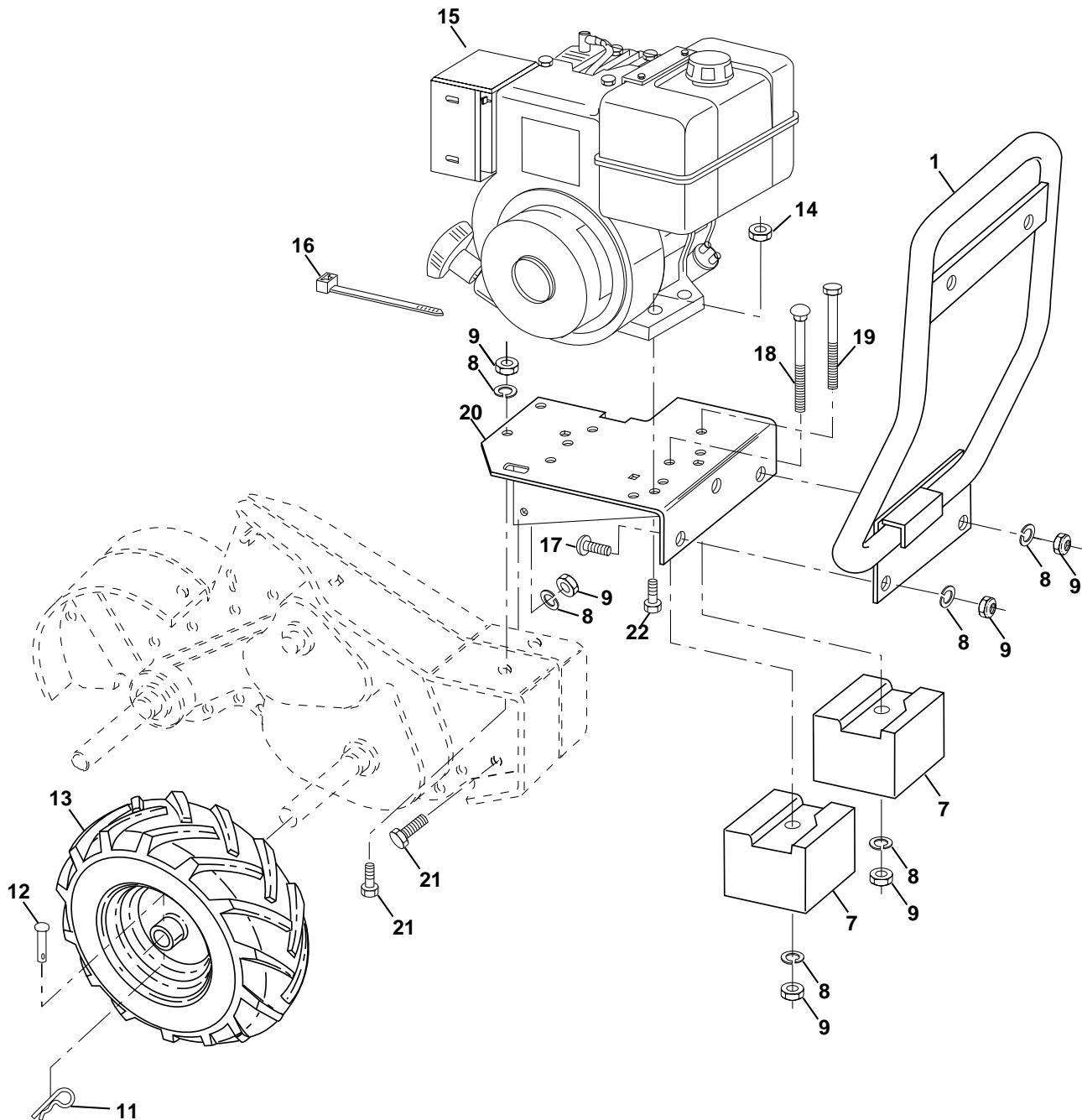

KEY NO.	PART NO.	DESCRIPTION
1	532138402	Bumper
7	532008450	Counter Weight, R.H.
8	810040600	Washer, Lock 3/8
9	873220600	Nut, Hex 3/8-16
11	532124961	Clip, Hairpin
12	532004929	Rivet, Drilled
13	532005015	Tire
	532124366	Rim
	532124718	Tire Valve
14	873510500	Nut, Keps 5/16-18
15	-----	Engine, Briggs & Stratton Model No. 196402

KEY NO.	PART NO.	DESCRIPTION
16	532007192	Tie, Cable
17	872140608	Bolt, Carriage 3/8-16 x 1
18	872470636	Bolt, Carriage 3/8-16 x 4-1/2
19	874760672	Bolt, Hex Head 3/8-16 x 4-1/2
20	532138669	Bracket, Engine
21	874760616	Bolt, Hex Head 3/8-16 x 1
22	874760528	Bolt, Hex 5/16-18 x 1-3/4
--	532166071	Starter Kit B & S (Optional)

NOTE: All component dimensions given in U.S. inches.
 1 inch = 25.4 mm

REPAIR PARTS

TILLER -- MODEL NO. CRT83 (954140066C), PRODUCT NO. 954 14 00-66

TRANSMISSION

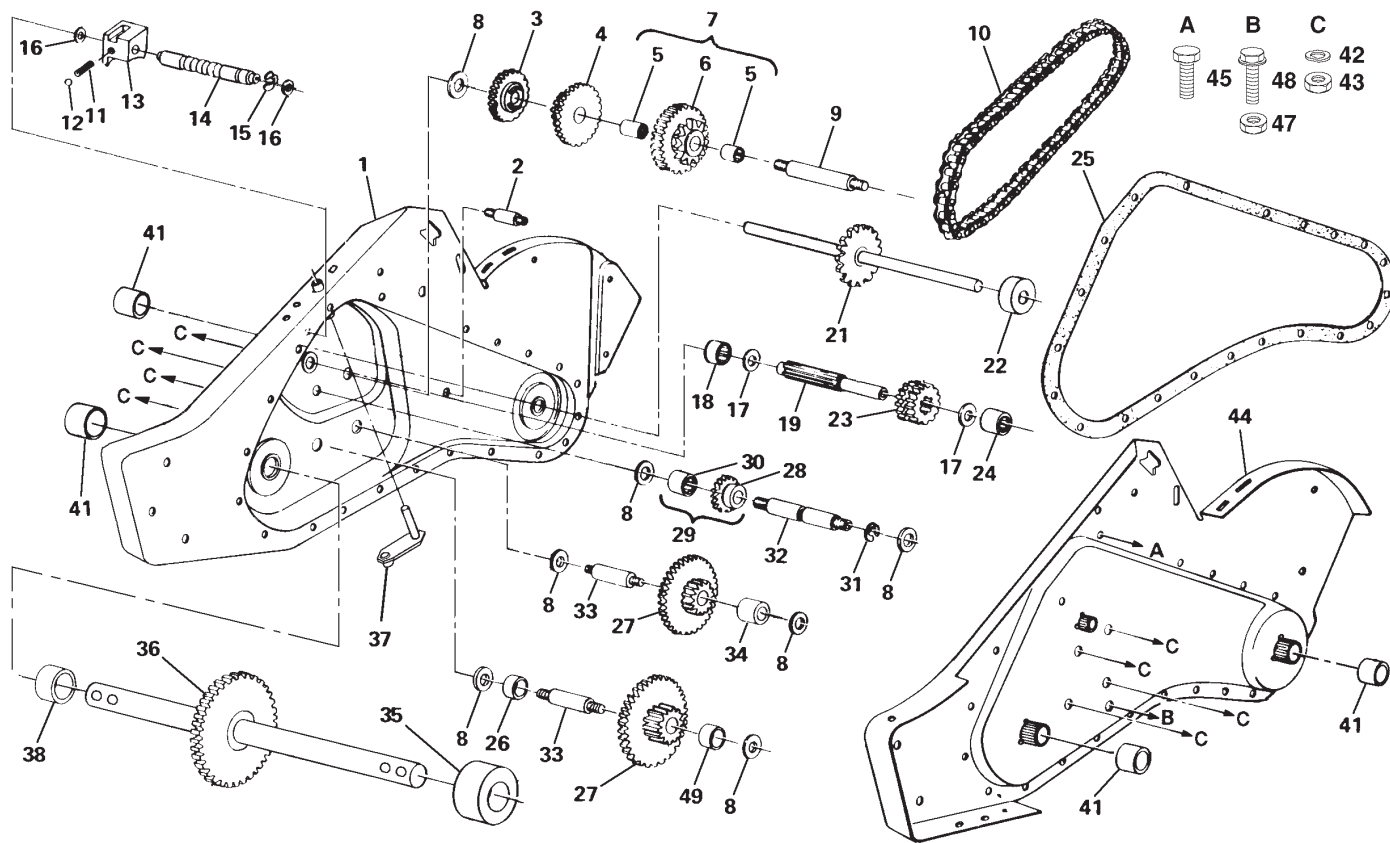

KEY NO.	PART NO.	DESCRIPTION	KEY NO.	PART NO.	DESCRIPTION
--	532170324	Transmission Assembly	26	532106389	Spacer .765 I.D. x 1.12 x 5/8
1	532170325	Gearcase Assembly, R.H., with Bearing (Includes Key No. 18)	27	532100433	Gear, Cluster, Red., 2nd and 3rd
2	532008370	Bolt, Upset	28	532008357	Gear, Reverse Idler
3	532008547	Gear, Reverse	29	532144562	Gear Assembly, Reverse Idler (Includes Key Numbers 28 and 30)
4	532008546	Gear, Cluster, Red., 1st and 2nd	30	532006803	Bearing, Needle
5	532100413	Bearing, Needle	31	812000040	Klip Ring
6	532144564	Sprocket Assembly, Tine	32	532008356	Shaft, Reverse Idler
7	532144563	Sprocket Assembly with Bearings (Includes Key #6 & two of Key #5)	33	532100016	Shaft, Reduction, 2nd
8	532004358	Washer	34	532106392	Spacer .765 I.D. x 1-1/8 x 1-3/8
9	532008358	Shaft, Reduction, 1st	35	532106394	Spacer, Ground Drive, L.H.
10	532008371	Chain, Roller, 60P	36	532100436	Shaft Assembly, Ground
11	532100371	Spring, Shift, Fork	37	532142145	Arm Assembly, Shift
12	532124697	Ball, Steel	38	532106393	Spacer, Ground Drive, R.H.
13	532008353	Fork, Shift	41	532155236	Seal Asm Oil
14	532008354	Shaft, Shift	42	810040700	Washer, Lock 7/16
15	812000039	Klip Ring	43	873610700	Nut, Hex 7/16-20
16	532154467	Washer, Seal	44	532162165	Gearcase Assembly, L.H., with Bearing (Includes Key Number 24)
17	532001370	Race, Bearing, Thrust, 5/8 I.D.	45	817720510	Screw, Thd Cut 5/16-18 x 5/8
18	532124792	Bearing, Needle	47	873220500	Nut, Hex Head 5/16-18
19	532150695	Shaft, Input	48	532100107	Screw, Whiz-Lock 5/16-18 x 4
21	532105378	Shaft Assembly, Tine	49	532106391	Spacer .765 I.D. x 1.12 x 3/4
22	532106181	Spacer 1.008 x 1-3/4 x .645	--	532006066	Grease, Plastilub Number 1
23	532008359	Pinion, Input	--	532162170	Kit, Gearcase LH and RH w/Bearing
24	532005020	Bearing, Needle			
25	532164396	Gasket, Gearcase			

NOTE: All component dimensions given in U.S. inches
1 inch = 25.4 mm

REPAIR PARTS

TILLER -- MODEL NO. CRT83 (954140066C), PRODUCT NO. 954 14 00-66

TINE SHIELD

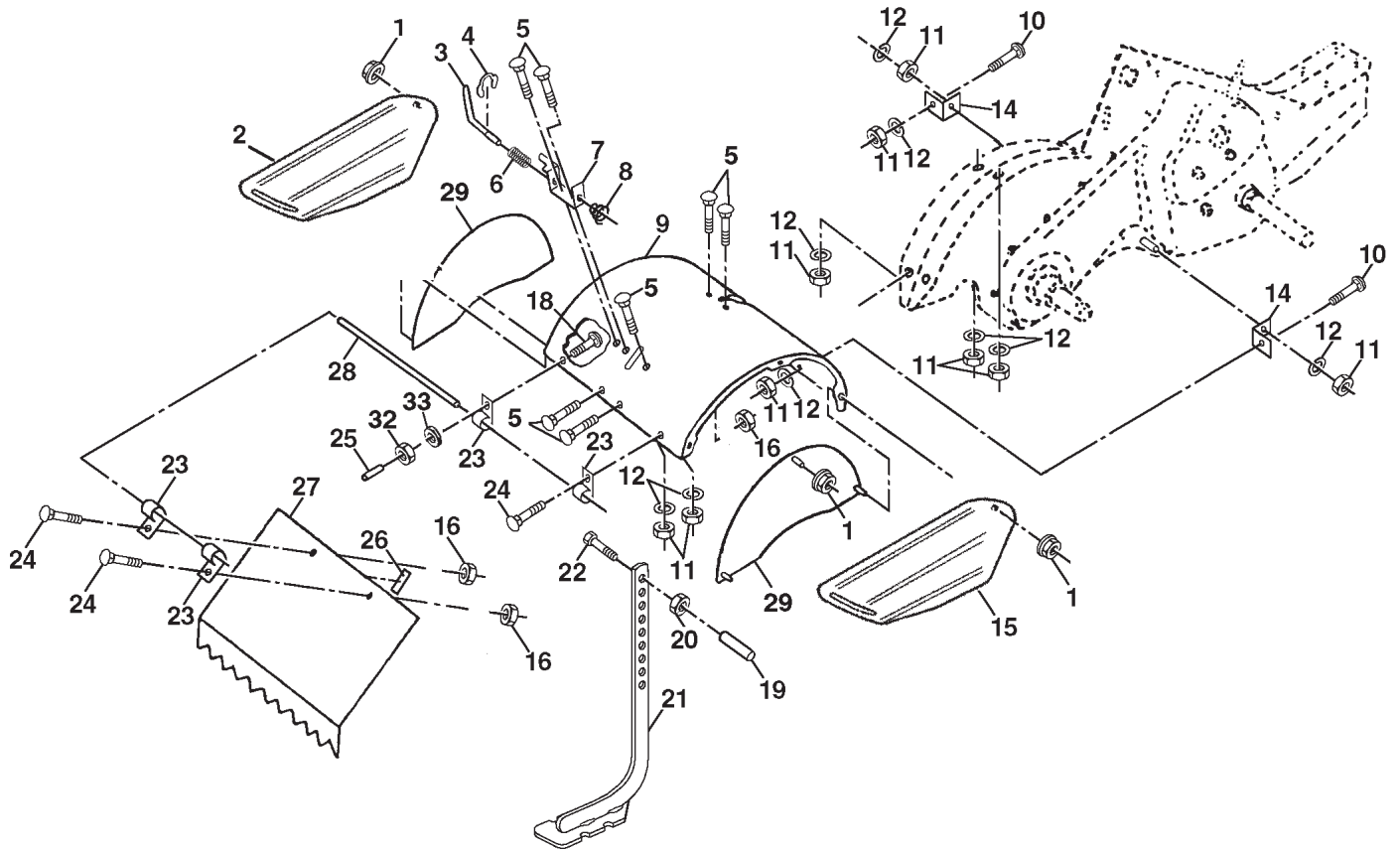

KEY NO.	PART NO.	DESCRIPTION
1	873900500	Nut, Lock Hex Flange 5/16-18
2	532163560	Shield, Side, Outer, L.H.
3	532008393	Pin, Depth Stake
4	812000036	Ring, Klip
5	872140508	Bolt, Carriage 5/16-18 x 1
6	532008394	Spring
7	532008392	Bracket, Latch
8	532109230	Spring, Depth Stake
9	532171616	Shield, Tine
10	872140506	Bolt, Carriage 5/16-18 x 3/4 Gr. 5
11	873220500	Nut, Hex 5/16-18
12	810040500	Washer, Lock 5/16
14	532008386	Bracket, Shield Tine
15	532163561	Shield, Side, Outer R.H.
16	873900400	Nut, Hex, Flange 1/4-20 UNC

KEY NO.	PART NO.	DESCRIPTION
18	872040410	Bolt, Carriage 1/4-20 x 1-1/4 Gr. 5
19	532102701	Grip
20	873220600	Nut, Hex 3/8-16
21	532138420	Stake, Depth
22	874930632	Bolt, Hex 3/8-16 x 2
23	532004440	Hinge
24	872140404	Bolt, RDHD SQNK 1/4-20 x 1/2
25	532124717	Cap, Vinyl
26	532109227	Pad, Idler
27	532145520	Shield, Leveling
28	532138609	Pin, Hinge
29	532145521	Shield, Side
32	873220400	Nut, Fin, Hex 1/4-20 UNC
33	810040400	Washer Lock 1/4

NOTE: All component dimensions given in U.S. inches.
1 inch = 25.4 mm

REPAIR PARTS

TILLER - - MODEL NO. CRT83 (954140066C), PRODUCT NO. 954 14 00-66

TINE ASSEMBLY

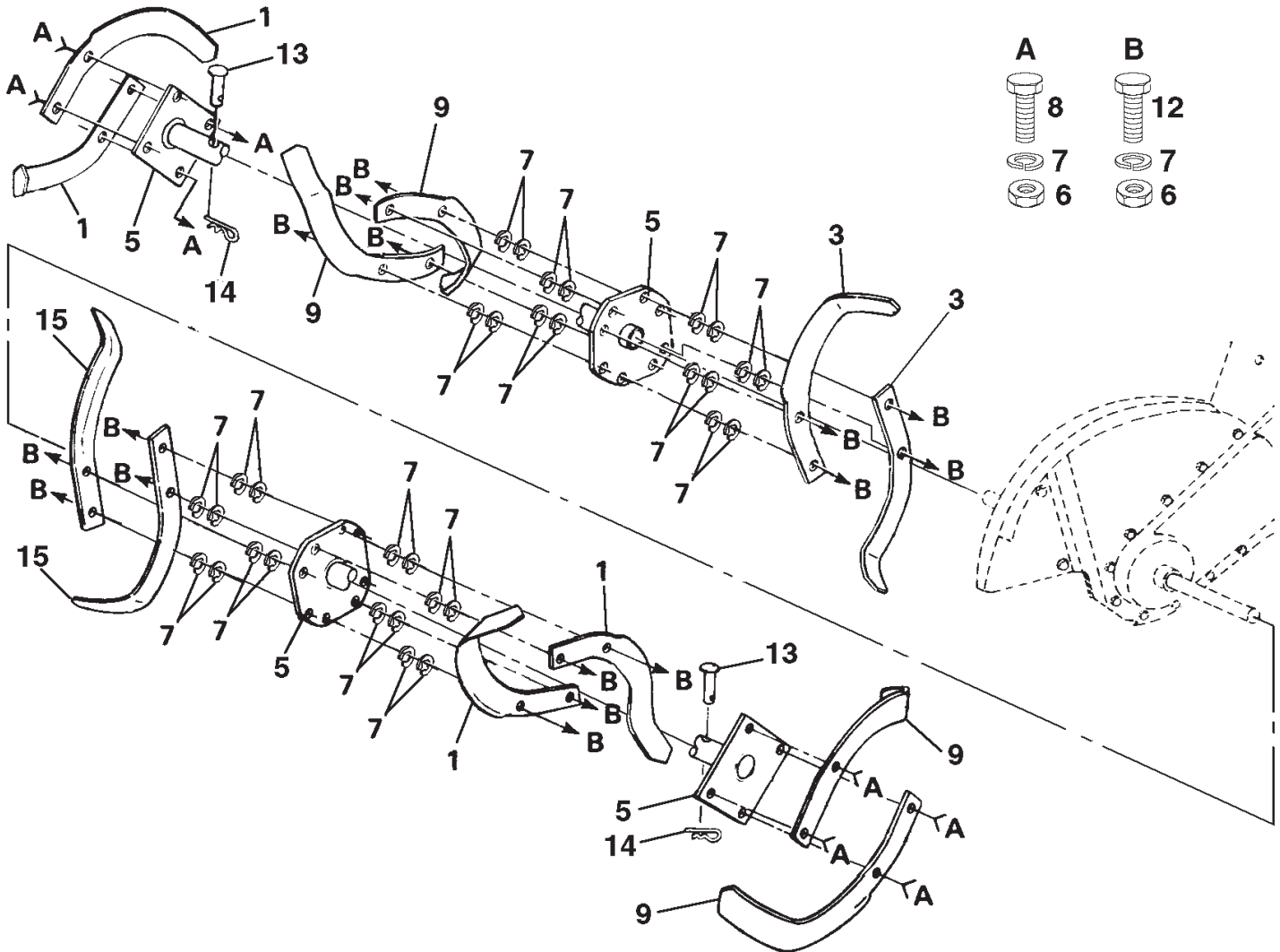

KEY NO.	PART NO.	DESCRIPTION
1	532006556	Tine, L.H., 14"
3	532101194	Tine, L.H., 14"
5	532100445	Hub Assembly
6	873610600	Nut, Hex 3/8-24
7	810040600	Washer, Lock 3/8
8	874610616	Bolt, Hex Head 3/8-24 x 1
9	532006557	Tine, R.H., 14"
12	874610624	Bolt, Hex Head 3/8-24 x 1-1/2
13	532004929	Rivet, Panhead
14	532003146	Clip, Hairpin
15	532101193	Tine, R.H., 14"

NOTE: All component dimensions given in U.S. inches.
1 inch = 25.4 mm

REPAIR PARTS

TILLER - - MODEL NO. CRT83 (954140066C), PRODUCT NO. 954 14 00-66

DECALS

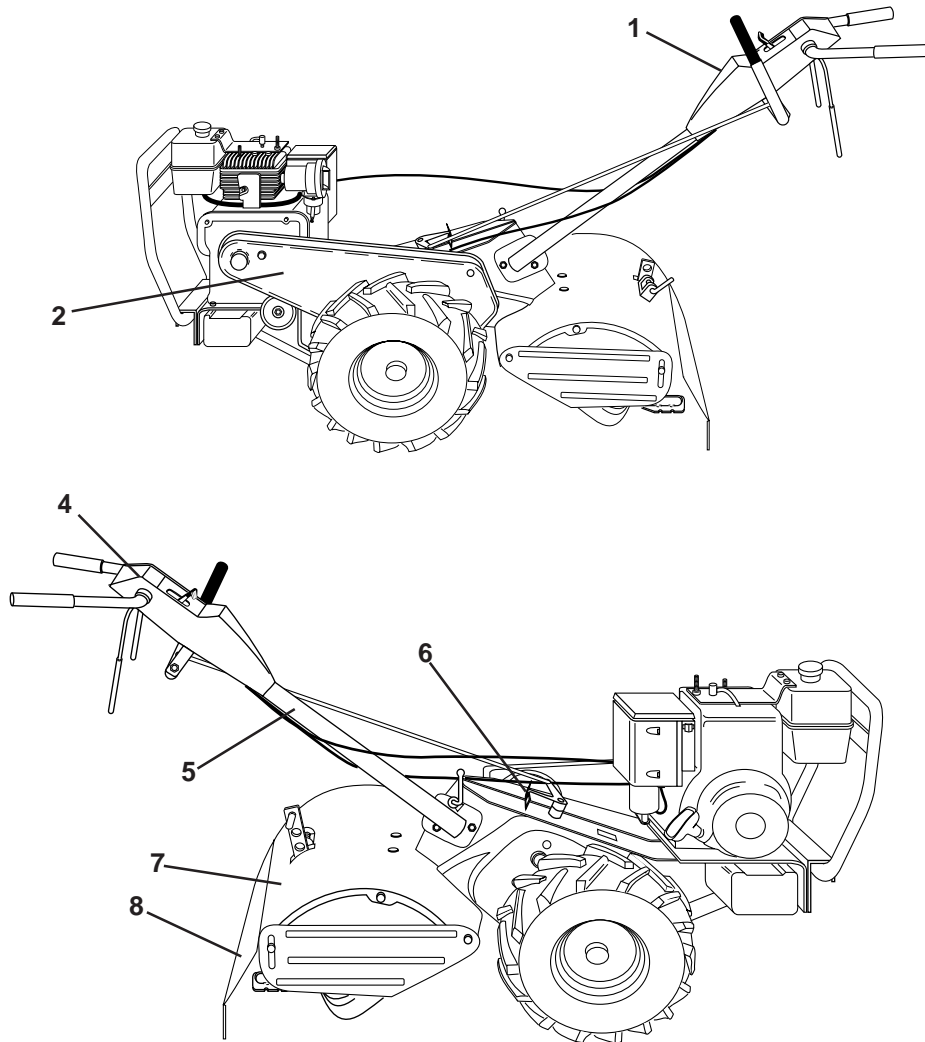

KEY NO.	PART NO.	DESCRIPTION
1	532155449	Decal, Logo
2	532162380	Decal, Logo
4	532156536	Decal, Instruction, Tilling
5	532110614	Decal, Hand Placement
6	532138546	Decal, Shift Indicator
7	532162384	Decal, Caution
8	532120076	Decal, Warning, Rotating Tines
--	532170621	Manual, Owner's(English)
--	532170622	Manual, Owner's(French)